

Overview

The in-line modular TAMs are designed to plug straight into the DSLAM, but due to the DSLAM construction this is not possible as the module extends outside the cabinet. When space is available within the DSLAM rack an Internal Shelf is utilised to house the Lucent modules. Should there be no space available, the shelf will fit in a standard ETSI rack. The Modules are inserted in the shelf.

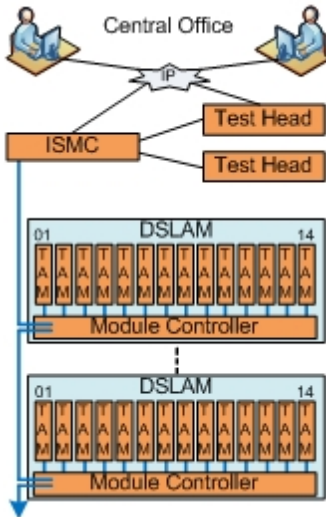

The DSLAM cable is connected to the DSLAM side of the module and a tie cable fitted to the other side and returned to the DSLAM. Retrofit takes less than an hour, the cables are removed from the Module, the modular TAM replaced and the cables re-connected. The installation teams will be provided with all the tools required to carry out a retrofit installation.

Daisy chain up to 32256 lines with an ISMC 32ES-EU or 129024 with the ISMC 128ES-EU

Key Benefits

- Low cost solution at install time or as a retrofit option
- Automated testing after floods, storms or weather disasters
- Reduced truck roll by accurate fault diagnosis
- Reduced OpEX, more efficient use of deskilled staff
- Self contained rack expansion kits available



Key Features

- Modular design, no additional racks or footprint
- No power consumption in idle mode
- True four wire test - 2 in, 2 out
- Fault tolerant - lines switched through by default
- EMC, ESD, RoHS, CE compliant

Product Data

- 72 Switchable test circuit pairs per module
- Height: 350mm Width: 20mm Depth: 105mm Weight: 540g
- Four wire test bus - look in & look out test option
- Real Time circuit access, test and diagnostics
- Fault tolerant - lines switched through in default
- Free API & XML interface for customer control system
- RJ45 Cat 5 cables provided for easy interconnect
- Works with all leading manufacturers Test Heads
- Fully compliant with EMC, ESD, CE and RoHS standards

